

Rotherham

Interim Planning Statement

Rotherham Achieving



Shopfront Design Guide

July 2006

Background

The design guide will eventually be formalised as a Supplementary Planning Document (SPD) and form part of the Local Development Framework. However until the Council considers that it is in a position to achieve this, it will be adopted as an Interim Planning Statement which can be taken into account when determining planning applications.

This does not have the full weight of SPD; however preparation and consultation will follow the requirements set out in The Town and Country Planning (Local Development) (England) Regulations 2004 (the Regulations).

In accordance with regulations 17 and 18 of the Regulations this document sets out the consultation and public participation processes associated with preparing and adopting the design guide and the statement of adoption. This includes details of the formal consultation exercise undertaken and a consideration of the comments received and proposed changes to the draft design guide.

Consultation

The consultation exercise has been devised in accordance with the RMBC consultation protocol, guidance in Planning Policy Statement 12: Local Development Frameworks and The Town and Country Planning (Local Development) (England) Regulations 2004. It will also have regard to the Statement of Community Involvement.

Consultation has included the Access Liaison Group with reference to the needs of people with varying disabilities.

The draft design guide was published for consultation for a six week period, which ended on 25th May 2006. Press notices were placed in the South Yorkshire Times and the Rotherham Advertiser on 13th / 14th April and on 11th / 12th May 2006.



Contents

Introduction	4
Legal Requirements	6
Development Control Checklist	7
The Principles of Good Shopfront Design	8
<i>Shopfront Design Elements -</i>	
Signs	10
Doors and Thresholds	13
Security	14
Canopies and Blinds	15
Lighting	16
Materials and Decoration	18
Glossary	19
Conservation Development	20



Introduction

Aims of the Guide

This document has been produced to act as a borough wide guide to encourage good quality shopfront design. The design of shopfronts has a major role to play in creating a quality environment. It is important that they should not compromise the local character, scale and architectural quality of the individual buildings.

The local planning authority is keen to encourage both the reinstatement of historic shopfronts and the provision of contemporary designs with flair. This is a guide for designers and applicants as to how best to achieve this.

This document aims to secure improvements to the visual quality of shop frontages. It promotes good shopfront design that celebrates the character and architectural detailing of the original buildings to improve the townscape which will benefit all the traders and the community as a whole.

The Council is committed to creating town centres that will be welcoming and attractive, projecting an image of quality and friendliness that will bring shoppers back into the town centre.

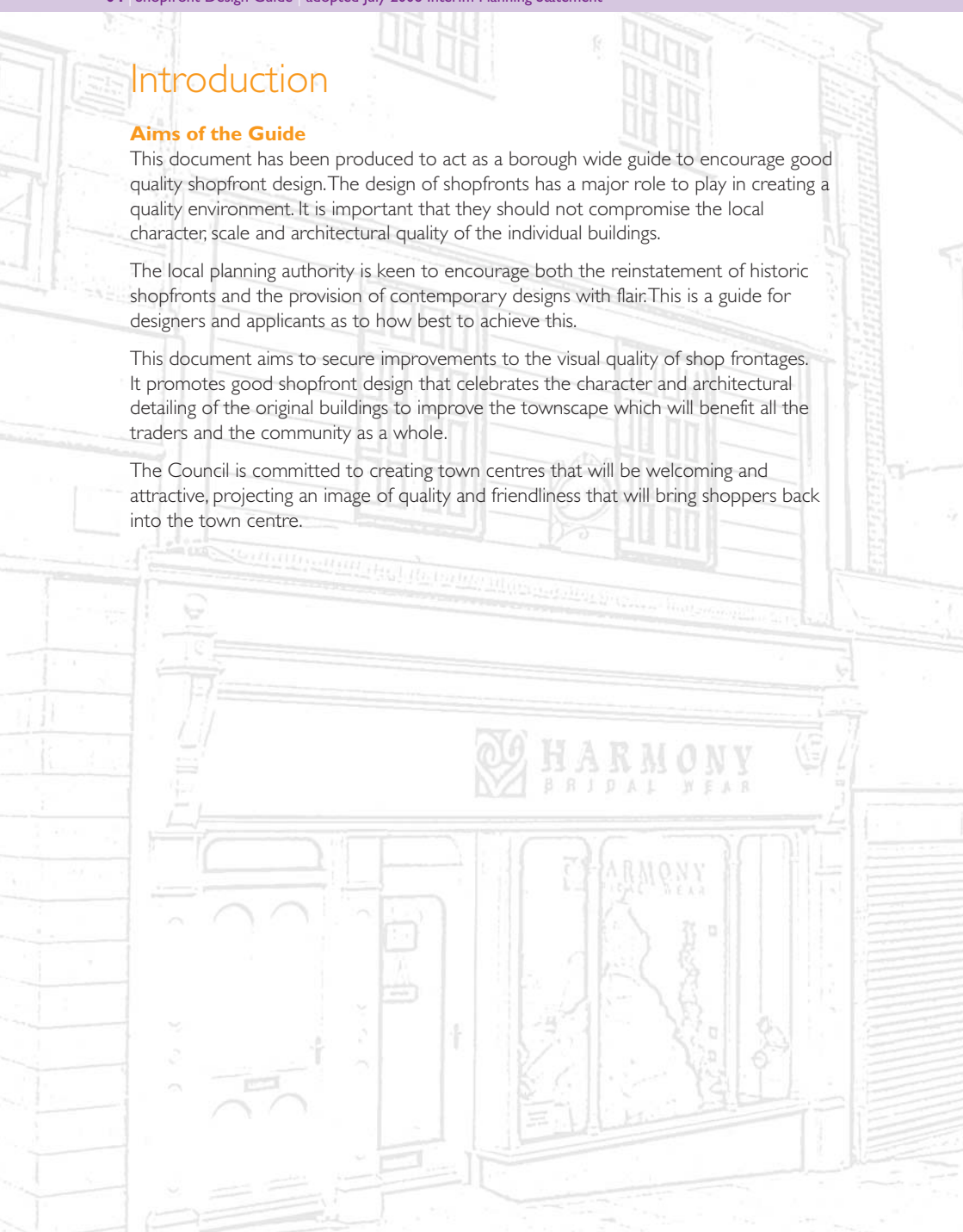



Rising above the shop frontages there is an abundance of beautiful old buildings of differing styles and materials which have sufficient architectural merit to provide a backdrop to any vibrant community.

Legal Requirements

Planning Permission

is required for all shopfronts which are to be altered or replaced. This includes altering the glazing, changing facing materials, installing blinds or external shutters or enlarging the size of a fascia. The list is not exhaustive and in each case the Council should be contacted for advice prior to commencing any work.

Listed Building Consent

is required for any alterations which would affect the character of the listed building. This includes re-painting a shopfront in a different colour; installing blinds or shutters, or installing a security alarm or extractor fan.

Conservation Areas

are areas of special architectural or historic interest and stringent controls are in place to protect buildings within those areas. Consent is required for the proposed or substantial demolition of any building in a Conservation Area including the removal of a shopfront.

Advertisement Consent

is needed for illuminated signs or fascias, projecting signs and extra large signs above ground floor level. Detailed guidance is available in the 'Outdoor Advertisements and Signs' leaflet produced by the Department for Communities and Local Government www.communities.gov.uk

Building Regulation Approval

is required for new shopfronts when any alterations affect the buildings structural stability, means of escape or the position of the entrance approach and or doorway.

Before and after images of a listed Georgian building - 2005

The deep fascias on this listed Georgian house damage the proportions of the buildings



Requiring listed building consent, a more appropriate frontage was achieved during refurbishment with a narrow fascia and single word sign, back-lit at night.



The elegant frontage of this listed building on Wellgate has been respected with minimal signage used.

Development Control Checklist

Existing Streetscape

Has the relationship of the proposed development to the adjoining buildings been taken into consideration?

Building Elevations

Is the scale of the shopfront in proportion to the facade of the building?

Shopfront Design

Is the design and materials employed in the scheme of good quality?

Signage

Are the graphic design, advertisements and illumination appropriate to the scheme?

Canopies and Blinds

Have they been considered within the overall design of the shopfront?

Shutters

If shutters are required are they of a type and location that does not obstruct any architectural features on the building or have an adverse environmental impact? Are external shutters perforated and painted with the shutter box sited behind the fascia?

Access

Does the design allow access to all, including people with disabilities, in accordance with the Disability and Discrimination Act (DDA) 2005?

Drawings Required

- an existing elevation of the shop front and the building in which it is located, together with the adjoining properties - 1:50
- a proposed elevation of the shop front - 1:20
- cross sections of the building - 1:20
- details (e.g joinery profiles, signs etc) - 1:5
- information on materials, fittings and colours
- an access statement, setting out how the needs of disabled people have been taken into account

Use of traditional lettering found on buildings in the town centre



Principles of Good Shopfront Design

The starting point when contemplating a new or replacement shopfront will always be a study of the whole building facade and adjacent elevations, including any existing shopfronts.

Shopfronts for many people are the most visually important feature of a streetscene. It is therefore vitally important that they are of good proportions, details and materials.

Nineteenth century shopfront design was based on a set of principles which achieved a satisfactory relationship between the shopfront and the building as a whole.

The pilaster, stallriser, cornice and fascia combine to enclose the shop window and the entrance door within a frame constructed to proportions which suggest a method of support for the building facade above. The main elements are in proportion to each other; the height of the stallriser should not exceed 20% of the overall shopfront height, nor should the height of the entablature. These basic principles applied to traditional or contemporary shopfronts will result in an elevation which is visually pleasing.

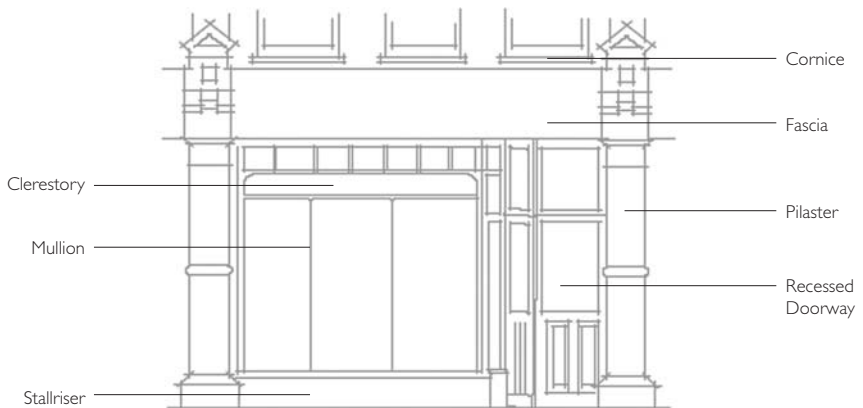
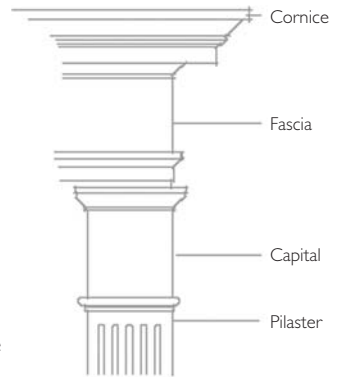

Standard and corporate shopfronts have in the past had little regard for individual buildings and it is recommended that a modest interpretation of the corporate image is adopted that relates better to the building. It is particularly important that poor quality pastiche reproduction shopfronts are avoided. New shopfronts of an imaginative and creative design are encouraged which may be complimentary in proportion, scale, quality of materials and detailing to the building itself.



Hamby's, High Street, Rotherham - A tasteful traditional shop front

- The style of the shopfront should harmonise with the age and character of the building as a whole.
- The scale of the shopfront should be in proportion with the rest of the building.
- An existing shopfront which contributes to the character of a building or area should be retained and refurbished rather than replaced. Any original features such as pilasters and fascias that have been concealed by later additions should be exposed and restored in order to enhance the appearance of the shopfront.
- It is important that the replacement shopfront respects the period and style of the building in terms of proportion and quality of materials and relate well to neighbouring properties.
- Where adjacent shopfronts are to be operated as a single concern then each shopfront should be individually expressed by retaining or reintroducing pilasters between them.
- Signage and security precautions should not exceed what is reasonably necessary to advertise the business and give protection against burglary and vandalism.
- Illumination of shop signs should be external rather than in the form of internally illuminated box signs.
- Any canopies should be incorporated within the overall design.
- Doorways and entrances should be accessible to people with disabilities.
- In general, door recesses should not be deeper than 600mm.

Shopfront Design Elements

Signs

- Shops are normally limited to one fascia sign and one hanging sign. The sign should be well designed to project a quality image. Multiple signage clutters the facade and must be avoided. Some signs require 'Advertisement Consent' from the Council.

Fascia Signs

- Fascias should be no deeper than 20% of the shopfront's overall height. They should not impinge on the original details of the shopfront.
- A traditional fascia comprising of a painted timber background with hand painted lettering is particularly appropriate for traditional shop fronts. Raised metal or timber letters are acceptable but garish shiny plastics are best avoided.
- Lettering and graphics should be moderately sized and should be in proportion to the dimensions of the fascia. Clear well spaced letters are as easy to read as larger oversized letters. The sign should be limited to the name of the shop with a simple graphic logo and the street number. Too much information creates visual clutter which will not be acceptable.
- Surface mounted box signs attached to the front of fascias detract from the appearance of the shop. They will not be permitted and alternatives should be considered.
- Where there is a small fascia or none at all, individual letters may be applied to the face of the building. Professional lettering may also be applied to hanging clear panels inside of the display window.



Imperial Buildings - A delightful, traditional streetscape

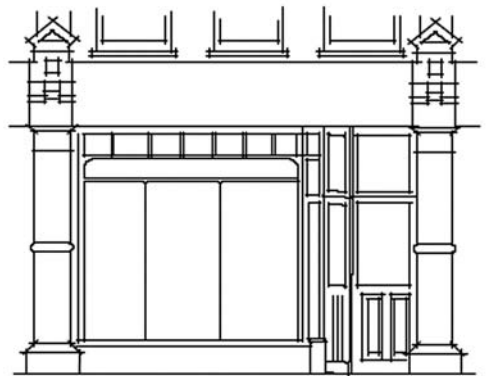

Fascias should be no deeper than 20% of the depth of the shopfront



Over use of signage clutters the facade



Unsympathetic lettering out of keeping with a Georgian Grade II listed building



Corporate signage having little regard for the building style

Hanging and Projected Signs

- As a general rule only one sign will be allowed per shop with an area no larger than 0.75m².
- Timber or cast metal signs are particularly appropriate on traditional shop fronts.
- The sign should be mounted
 - on a console at fascia level
 - on a pilaster below fascia level
 - below first floor cill level
- Projecting box signs will not be acceptable.
- Any illumination should be external not internal.
- Large scale detail drawings of proposed signs at a scale of 1:5 will be required with advertisement applications, clearly showing construction, lettering and graphic design.

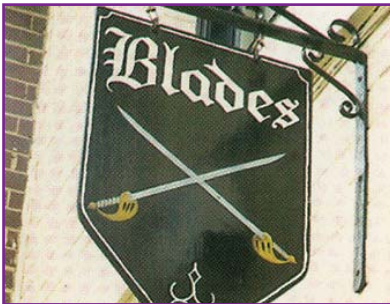
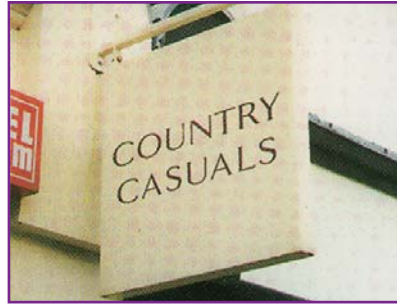

Traditional and contemporary hanging signs bringing variety to the street scene

Doors & Thresholds

The Disability Discrimination Act 1995 contains duties to make reasonable provisions and adjustments to premises to enable access & use for all.

Some of the Acts powers are implemented through Part M of The Building Regulations (Access to and use of buildings), which sets out statutory provisions for minimum standards relating to entrances to public & commercial buildings.

The document provides very specific guidance details for level, ramped or stepped access. Dimensions, characteristics and layout of doorways, including aspects of material finishes to be used, so as to enable access for people with limited physical dexterity and who are visually impaired.

These standards apply to all new buildings, extensions and building works to and about entrances, including historic buildings such as listed buildings.

Some common requirements include:

- 1.5 x 1.5M clear unobstructed level landing in front of the entrance door.
- If non-powered doors are used there should be an unobstructed space of at least 300mm on both sides of the pull side of the door.
- Where fitted with door opening furniture such as locks or leavers, the door can be opened with one hand formed as a closed fist.
- Thresholds are ideally level, but if raised, does not exceed 15mm.
- Doors in existing buildings have a minimum clear unobstructed opening of 775mm.
- Substantially glazed entrance doorways should be clearly identified with manifestations.



New ramp and steps create a fully accessible entrance set back from the street frontage

Security

Refer to 'Secured by Design' Section 17d Crime and Disorder Act, and the 'Guide to Security Standards for Doors and Windows' (May 2002) produced by the Loss Prevention Certification Board.

External Roller Shutters

- The addition of solid steel roller shutters is not acceptable. They can attract graffiti and create an undesirable hostile environment. Shutters will only be acceptable as a security measure if it can be demonstrated that there is no other alternative, and the shutter box is located behind the existing fascia and not protruding out onto the street; and if the shutter itself is perforated and either powder or plastic coated in a colour to match the shopfront.

Internal Shutters

- Internal shutters are preferred as a visible form of security without destroying the character of the original shopfront. They should be perforated lattice grilles, powder or plastic coated. Planning Permission is not required for internal shutters.

Toughened and Laminated Glass

- Windows without shutters create a more welcoming street scene as illuminated window displays are maintained at night. Security is provided without compromising the appearance of the property, by the use of laminated glass (6.8 mm thick is recommended).



Preferable internal shutter



Unacceptable exterior solid shutter

Reinforced stallrisers

- The reinforcement strengthens the shop front frame and reduces the risk of ram raiding.

Steel framed shop fronts

- This is an unobtrusive way to strengthen the shop front and reduces the risk of ram raiding.

Burglar alarms

- Burglar alarm boxes should not conceal architectural features or be positioned too conspicuously. Associated wiring should be hidden or at least neatly fixed. All fixings should be made of non-ferrous materials.

Canopies & Blinds

- Blinds serve to protect perishable goods from deterioration due to strong sunlight and help to keep the interior cool. Projecting roller blinds are the preferred option as they form an integral part of the shopfront and are retractable when not required.
- Dutch canopies are made from canvas or plastic over a metal frame. They hide architectural details and interrupt the building elevation. Shops have a tendency to leave them open which results in deterioration of the fabric and a scruffy appearance which is not acceptable.
- Highway regulations require the outer edge of the blind to be set back at least 1m from the kerb and the outer and inner ends of the supporting arms not less than 2.14 and 2.3m above the pavement.

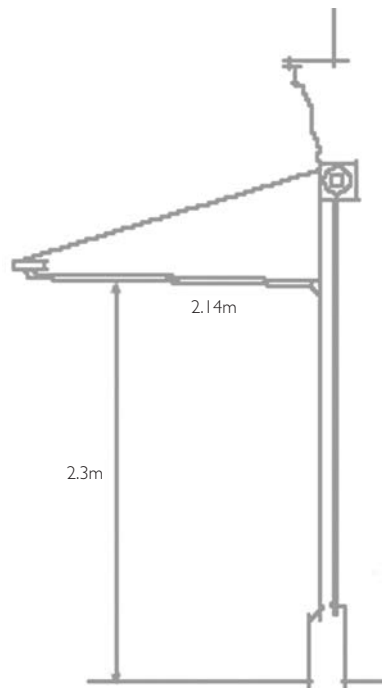

Lighting

Lighting should be considered as part of the overall design rather than ending up as a later ad-hoc addition. Subtle lighting can add vitality to the night-time street scene but poorly designed bulky illuminated signs can look brash. Over illumination must be avoided as it can upset the balance of light and conflict with street lighting.

Fascia Illumination

Fascia illumination, where it is required, should be considered as part of the street scene. Internally illuminated fascias are not acceptable as they create excessive glare. A variety of subtle lighting styles will add interest.

External lighting

Ideally light sources should be concealed, and carefully directed at the sign, avoiding glare. Lamp types include tungsten halogen floods, tungsten spotlights, low voltage tungsten spotlights, swan-necked metal arms, and concealed fluorescent tubes.



A traditional example of fascia illumination



A contemporary example of subtle fascia illumination and lettering

Backlit lettering

Translucent plastic letters or graphics are inset into an opaque panel which is illuminated from behind. The light box must be fully recessed behind the fascia.



An excellent of stylish backlit lettering and graphics

Individual halo letters

Individual letters stand proud of a surface and are lit from behind to produce a halo effect; a treatment which is suitable for fascias or wall mounting. Plastic lettering is not acceptable for old or listed buildings, quality individual letters in a suitable font and size are preferred.

Cool Cathode Tubes

Graphically elegant neon signs may be acceptable if they are of moderate size, single colour and limited palette.

Illumination of Hanging and Projecting Signs

Internal lighting

Old fashioned box illuminated signs are not acceptable. However, well crafted, elegant signs making use of thin fluorescent tubes so only the lettering or graphic is illuminated may be considered.

Alternative lighting

Tungsten lamps, backlit lettering or neon signs can prove acceptable alternatives. Careful design will be given consideration.

Building Illumination

Shop window display lighting contributes towards a safe night-time environment. Discrete spotlighting to highlight architectural features of a shop front or building is welcomed. Permission is not required unless the building is listed.





A traditionally painted historic facade

Materials and Decoration

- Use traditional materials such as painted timber wherever appropriate.
- Modern contemporary materials.
- Avoid the use of acrylic sheeting, perspex, plastic, standard natural finish aluminium and unpainted softwoods.
- Avoid garish or lurid colour schemes.
- Traditional oil based paints and pigments should be considered for historic buildings.
- Monotone paint combinations can result in a stylish high quality scheme.
- Painted timber is preferable to stained or varnished hardwoods.
- Refer to paint manufacturer's specialist historic colour charts for properties of a specific period.
- Ensure the colour scheme does not jar with its' neighbours.
- Colour contrast should be employed in accordance with the requirements of the DDA.

Entablature

The combination of cornice, fascia and architrave.

Cornice

Decorative moulded projection above the fascia providing weather protection and giving a strong line at the top of the shopfront.

Fascia

The wide board over the shopfront which provides the advertising space.

Architrave

A recessed plane of one or more horizontal mouldings whose function is to 'finish off' the bottom of the fascia.

Window

Glazing of a size appropriate to the design of the building as a whole. Avoid overlarge expanses of glass which are expensive to replace.

Stallriser

Vertical surface giving protection at ground level to the shopfront, providing a solid base. They are made of polished granite, marble, tile or wood and provide a cill for glazing.

Pilaster

Traditional shopfront dividing column between adjoining properties, designed with a base and capital, which supports the console and fascia.

Console

Bracket which frames or contains the end of the fascia panel. Provides a key element in maintaining the vertical rhythm of the streetscape.

Fanlight

A window above a door.

Doors and doorways

Recessed, in keeping with other elements with a return which matches the stallriser.

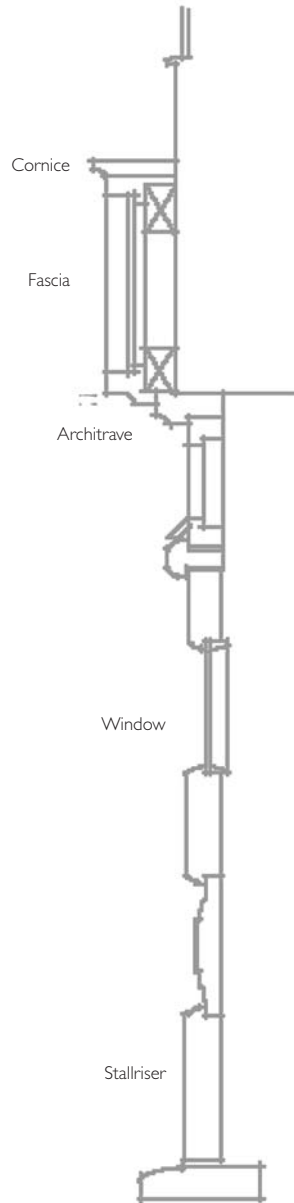

Development within Conservation Areas

Past Tense!

16 High Street c.1900

Historic Photo from the
RMBC Archives



16 High Street, Summer 2005





Present and Correct

Conservation shop front
designs commissioned by
the Council, Spring 2005

A new specialist shop on High
Street, opened December 2005







Supported by

The National Lottery[®]
through the Heritage Lottery Fund



Heritage
Lottery Fund



ENGLISH HERITAGE



2002-2003
Fostering Business Growth
2003-2004
Removing Barriers to Work
2005-2006
Supporting New Businesses



2005-2006
Asset Management
2006-2007
Valuing People
Delivery of Quality Services
Through Procurement